

# BOOTH SPECIFICATIONS

For questions regarding booth specifications, please contact Show Management at 972.536.6415. To avoid additional costs (i.e. design cost or tear down of an unapproved structure) please obtain written approval before beginning production or construction of display. All requests must be in writing; e-mail to [Help@TheRoofingExpo.com](mailto:Help@TheRoofingExpo.com) or fax to 972.536.6410.

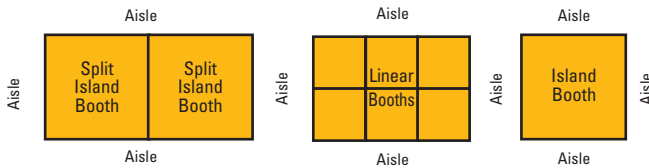

## Booth Equipment

Standard 10'x10' Linear Booths will be set with an eight foot (8') high back drape and three foot (3') high side drape.

## Linear (In-Line) Booths

Linear Booths have only one (1) side exposed to an aisle and have at least one adjacent neighbor on either side of the booth.

### Dimensions and Use of Space

Linear Booths are most commonly ten feet (10') wide and ten feet (10') deep, i.e. 10'x10'. Regardless of the number of Linear Booths utilized, (i.e. 10'x20', 10'x30', 10'x40', etc.) display material, signage, equipment and product should be arranged in such a manner so neighboring exhibitors' sight lines are not obstructed. The maximum height of twelve feet (12') is allowed only in the rear half of the booth space, with a four foot (4') height restriction imposed on all materials in the remaining space forward to the aisle. Note: When three (3) or more Linear Booths are used in combination as a single booth space, the four foot (4') height limitation is applied only to that portion of booth space which is within ten feet (10') of an adjoining booth. Hanging signs from the ceiling are NOT allowed in any Linear Booth configuration.

Any display material, signage, equipment and product over 8' 3" must be professionally finished or draped on the back. Show Management will determine what is considered professionally finished. Signs, banners, logos, images, symbols or flags are not permitted on the backside of the backwall or sidewall facing neighboring booths.

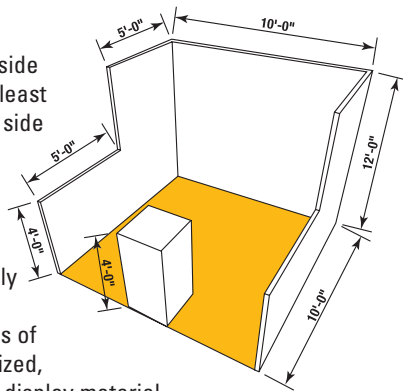

## Perimeter Booth

A Perimeter Booth is simply a Linear Booth that backs to a wall of the exhibit facility rather than to another booth.

### Dimensions and Use of Space

All guidelines for Linear Booths apply to Perimeter Booths except that the backwall height allowed in the rear half of the booth is sixteen feet (16') for display material, signage, equipment and product.

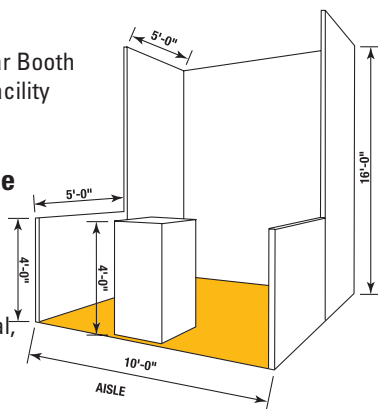

## Island Booth

An Island Booth is any size booth exposed to aisles on all four (4) sides.

### Dimensions and Use of Space

An Island Booth is typically twenty feet (20') wide by twenty feet (20') deep or larger, although it may be configured differently. Display material and signage will be permitted up to a maximum height of twenty-two feet (22') when ceiling height permits. Unlimited height for equipment and product is permitted throughout the booth. Stacking product over the twenty-two foot (22') height limit is not permitted.

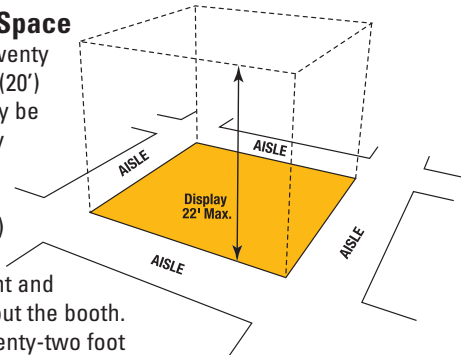

## Split Island Booth

A Split Island Booth is an Island Booth which shares a common backwall with another Island Booth.

### Dimensions and Use of Space

Display material, signage and backwall will be permitted up to a maximum height of twenty-two feet (22') when ceiling permits. Unlimited height for equipment and product is permitted throughout the booth. No signage is permitted on the backside of the backwall. Stacking product over the twenty-two foot (22') height limit is not permitted.

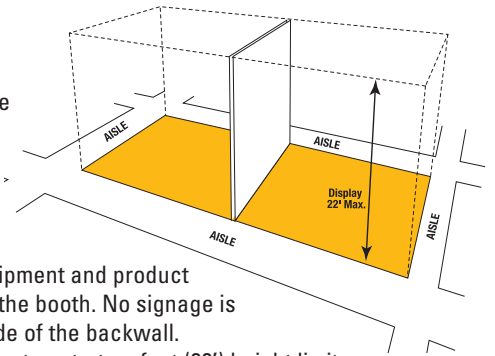

## Canopies

Exhibitors using canopies or false ceilings over their booth may use vertical supports up to three inches (3") in width in the corners of their space. Vertical supports which are strictly decorative, will not be permitted. Fire and safety regulations govern the use of canopies, ceilings and other similar coverings.

## Hanging Signs

Hanging signs will be permitted in Island and Split Island Booths (minimum of 400 sq. ft.) at a 22' maximum from floor to top of sign. Signs may be hung from the ceiling (where permitted), trusswork or equipment. Signs that will be hung from the ceiling or trusswork must be installed and dismantled by the Rigging Crew. For questions on hanging signs, please call Show Management at 972.536.6415

## Unfinished Walls

Any unfinished walls are subject to review by Show Management. Should Show Management deem the backside of the booth "unsightly" and/or does not conform to the overall quality of the show, the exhibitor may be required to drape the backside of the booth at the exhibitor's expense.

**Note:** Regulations for products being featured in booths differ from the booth display regulations. If your product does not meet booth specifications, please call Show Management at 972.536.6415.